

# Type 641/642 Galvanized Twinslot 200

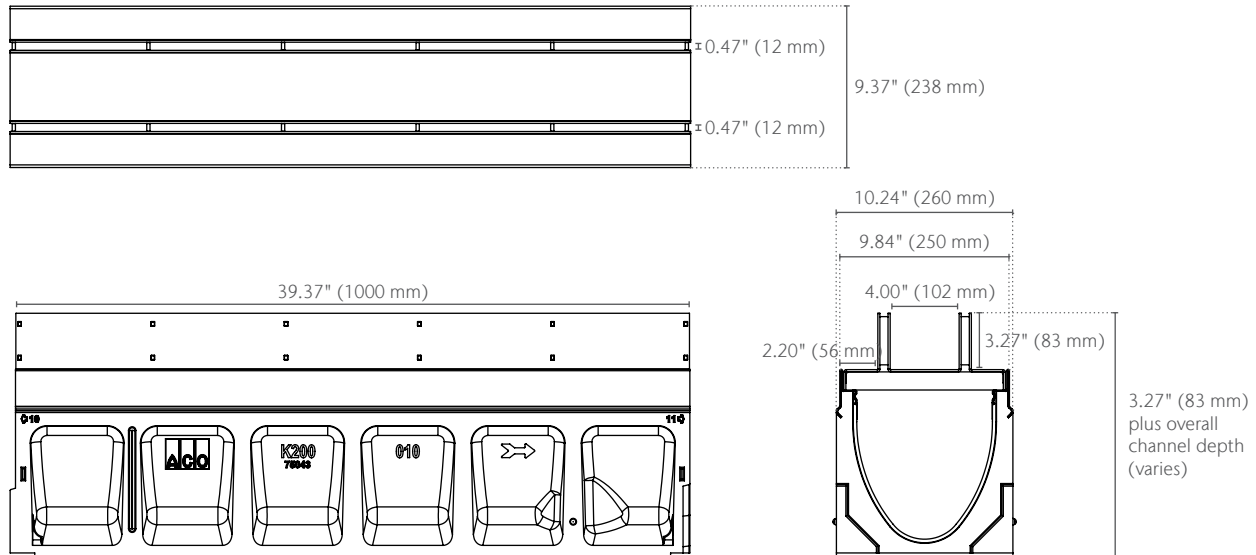

## One Meter Unit

part no. 138060



## Half Meter Unit

part no. 138061

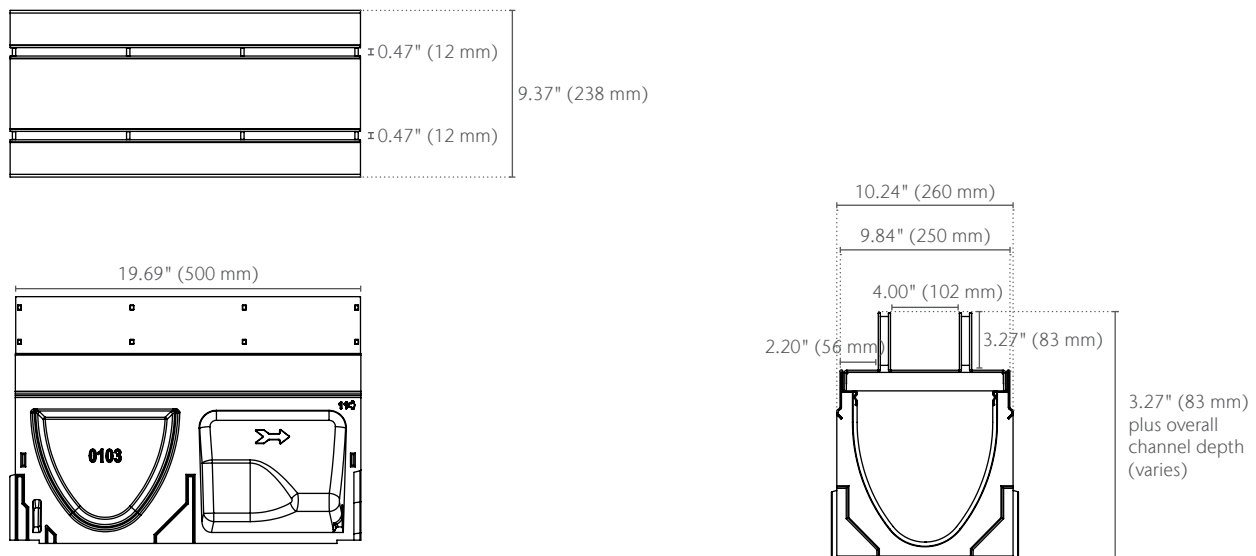

# Type 641/642 Galvanized Twinslot 200



Product Name	Part No.	Invert in (mm)	Weight lbs
Type 641/642 - Twinslot 200 - 39.37" (1 m) Galvanized Steel	<b>138060</b>	4.45 (113)	36.3
Type 641/642 - Twinslot 200 - 19.69" (0.5 m) Galvanized Steel	<b>138061</b>	4.45 (113)	18.7

**Note:**  
For use with K200 and KS200 channels, and Series 900 catch basins.  
Twinslot 200 can also be used with SlabDrain H2 and H2K channels.

## Specification Summary

### General

The surface drainage system shall be ACO Drain Brickslot, as manufactured by ACO, Inc. or approved equal.

### Installation

The trench drain system shall be installed in accordance with the manufacturer's installation instructions and recommendations.

### Materials

The Brickslot top is manufactured from 11 gauge galvanized steel.

The nominal clear opening for Twinslot are two ½" (12 mm) slots separated by 4" (102 mm) providing an overall width of 9.37" (238 mm). For use with K200, SlabDrain (H200K-13), and the K200 Series 900 catch basin. See separate ACO Spec Info Sheet for channel details.

Twinslot rests in the grate seating of the channel, the anti-shunt lugs help prevent lateral movement and the weight of covering material keeps the unit secured. Access units have frames that fit catch basins with a separate unit that can be removed for maintenance.



ADA-compliant per The Americans with Disabilities Act of 2010, Section 302.3



Australian Standard AS 3996 - 2006 Clause 3.3.6: max slot length dependent on slot width for grates that are deemed Bicycle Tire Penetration Resistant.



EN 1433 Load Class C  
56,202 lbs – 1,160 psi

## ACO, Inc.

© January 2026 ACO, Inc.

All reasonable care has been taken in compiling the information in this document. All recommendations and suggestions on the use of ACO products are made without guarantee since the conditions of use are beyond the control of the company. It is the customer's responsibility to ensure that each product is fit for its intended purpose and that the actual conditions of use are suitable. ACO, Inc. reserves the right to change products and specifications without notice.

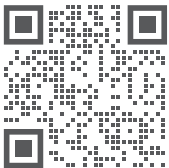

info@acousa.com  
www.acousa.com

